

## GHG-CV Cleanroom Hinge

### Features

- Plastic caps at rotating part prevent metal-to-metal friction and metal powder scattering
- When opening and closing door, plastic caps will not interfere with frame
- Aluminium alloy material, light weight and excellent design
- Round hole type, precision type and oval hole type available. For precision type, clearance between hinge leaves and plastic caps/shaft is small
- Suitable for semiconductor manufacturing equipment, clean room, aluminium frame, household equipment, etc.
- Passed 40,000 life cycle test

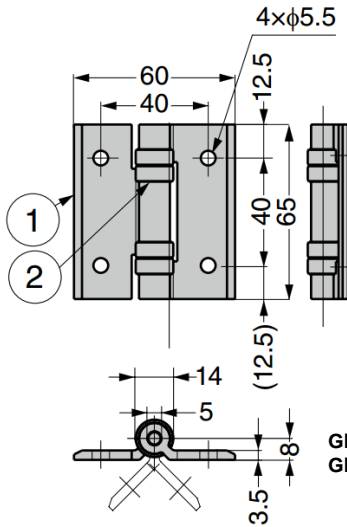
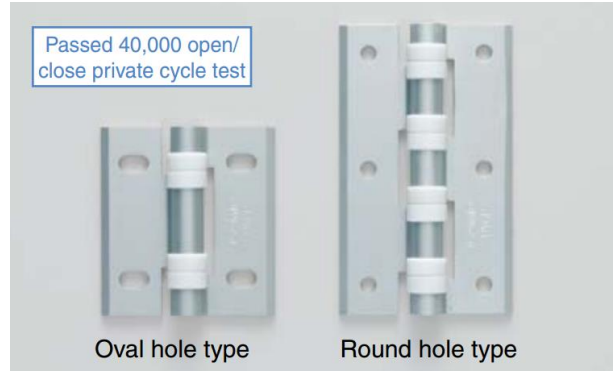

GHG-CV-65  
GHG-CV-65TNS

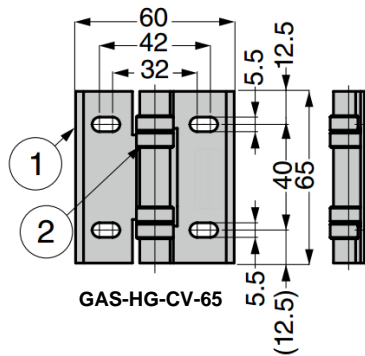

GAS-HG-CV-65

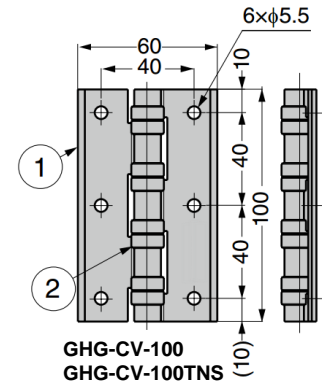

GHG-CV-100  
GHG-CV-100TNS

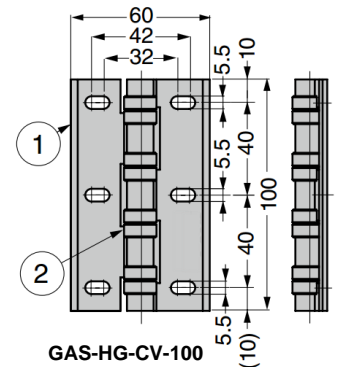

GAS-HG-CV-100

No.	Part Name	Material	Finish / Colour
①	Body	Aluminium Alloy	Anodised Silver
②	Cap	POM	White
-	Shaft	Stainless Steel (SUS303)	-

Part No.	Type	Load Capacity (per pair)	
GHG-CV-65	Round Hole Type	147 N	15 kg
GHG-CV-100		226 N	23 kg
GHG-CV-65TNS	Precision Type	147 N	15 kg
GHG-CV-100TNS		226 N	23 kg
GAS-HG-CV-65	Oval Hole Type	147 N	15 kg
GAS-HG-CV-100		226 N	23 kg

Reference door weight with 2 pcs in case of door W600 x H800

- GHG-CV65: 8kg
- GHG-CV100: 13kg